

# T41J Jockey Pump Submittal Sheet

## Performance Curve

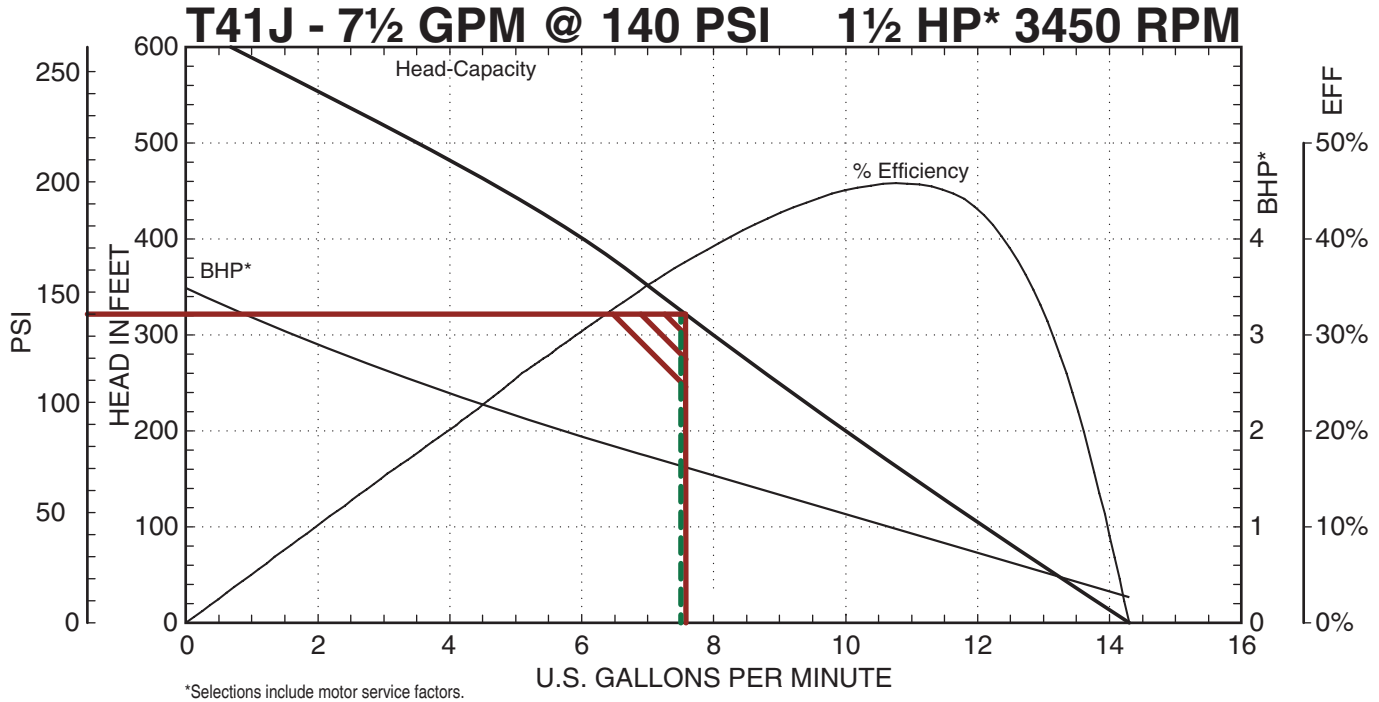

## Dimensions

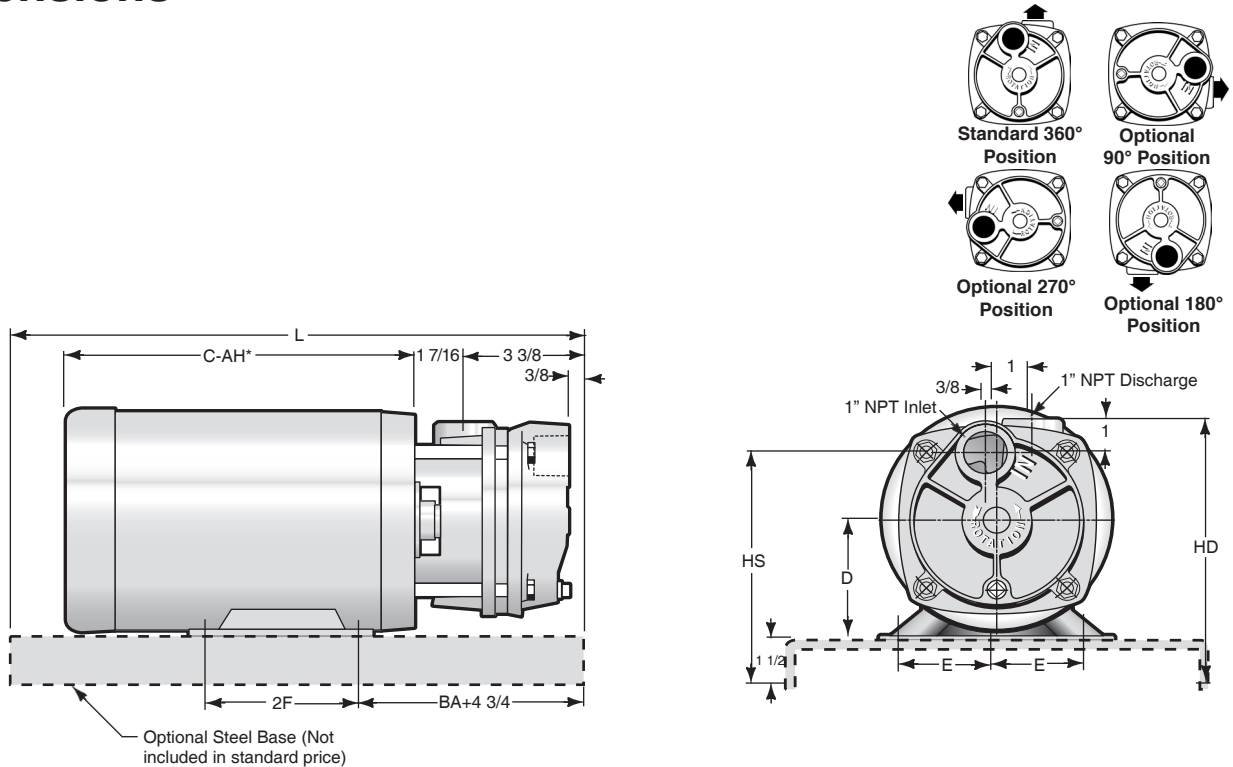

### 1 1/2 Horsepower Motor Dimensions

FRAME	D	BA+4 3/4	2F	E	H	HS	HD	L
56 C	3 1/2	7 3/8	3	2 7/16	5/16 - 18	7	8	18

#### NOTES

All dimensions in inches. May vary ± ¼ inches.  
 Not for construction purposes unless certified.  
 \*See motor dimensions for "C-AH" dimension  
 (Varies depending on motor enclosure).

© Copyright 2024 MTH Tool Company, Inc.



401 West Main Street • Plano, IL 60545-1436  
 Phone: 630-552-4115 • Fax: 630-552-3688  
 Email: SALES@MTHPUMPS.COM  
<http://WWW.MTHPUMPS.COM>

Dated April 2024

# Horizontal Close Coupled Design Specifications

The contractor shall furnish (and install as shown on the plans) an MTH T41 Series horizontal close coupled regenerative turbine type pump model T41J size 1" by 1" of bronze fitted construction. Each pump shall have a capacity of \_\_\_ GPM when operating at a total PSI of \_\_\_\_\_. Suction pressure will be \_\_\_ feet with a liquid temperature of \_\_\_°F.

The pump is to be furnished with a mechanical seal with stainless steel metal parts, Buna elastomers, ceramic seat and carbon washer. A stainless steel shaft or a shaft sleeve shall be furnished in pumps up to three horsepower and a 316 stainless steel shaft in pumps five horsepower and larger.

The pump casing shall be vertically split two piece, end suction and top discharge with water passageways accurately machined into each piece. The impeller shall be hydraulically self centering and no external adjustment shall be necessary.

The pump shall be close coupled to a standard NEMA "C" face 1 1/2 HP \_\_\_ phase \_\_\_ Hertz \_\_\_ voltage \_\_\_ RPM horizontal open drip proof motor. The motor shall be sized to prevent overloading at the highest head condition listed in the specifications.

## 1-Phase Bills of Materials

Item ID: 8C-T410JBFSCXSAXX-C511AD		
Item Description: T410J BF T21 Cer C/C 3/4 HP 1/60/115/208-230V 3450 RPM ODP Motor		
Item Number	Description	Qty Needed
12-1068-01-457	Type 21 Rotating Element .875" Buna Seal	1
1-2218-0J-543	T41 J Motor Bracket, Teflon Coated	1
2-2208-0J-543	T41 J Cover, Teflon Coated	1
17-1390-01-181	Sleeve, Shaft, Brass	1
15-1168-01-104	Setscrew, 18-8 SS	2
125-1282-01-592	Seal Seat, 0.875 Ceramic, O-Ring Style	1
22-4265-01-101	Plug, 1/8 SAE	1
135-1179-01-457	O-ring, -218 Buna Included w/ Seat	1
7-3970-01-457	O Ring, -902 Buna (Drain Plug)	1
7-2479-01-457	O Ring, -159 Buna	1
FRC-1246-51-ODP	Motor, 56C-Face, DLT Electric, 1.5 Hp, 1 Phase, 2 Poles, ODP CC	1
19-1997-01-080	Machine Bolt, 3/8-16 + 4"L	4
23-1487-01-080	Key, Sleeve	1
11-2228-0J-206	Impeller, T41J Bronze	1
23-1022-01-104	Drive Key, 316SS	1
14-1049-01-080	Drive Collar	1

## 1-Phase Motor Nameplate

<b>BLUFFTON MOTOR WORKS</b>		Blank:	
410 E. Spring St. Bluffton, Indiana 46714		MOD 1103007419	REF 124651-ODP
60 HZ	50 HZ	FR 56	PH 1
HP 1 1/2	1	INS 40	INS B
RPM 3450	2875	ENC D P	CONT
V 115/208-230	110/220	THE DATE	K
FLA 18.0/9.0	20.0/10.0	ISO CODE	DATE CODE
SF 13	1.0		
SFA 23.0/11.5	Blank		

TYPE THERMALLY PROTECTED

**HIGH VOLTAGE**

**LOW VOLTAGE**

TO REVERSE, INTERCHANGE ORANGE (5) AND RED (8).

**WARNING** - Always disconnect motor from power supply before servicing.

**THERMALLY PROTECTED AUTOMATIC RESET** - Motor will restart without warning after protector trips. Do not install this motor on equipment where an automatic start up could result in injury.

**GROUNDING** - Fatal electrical shock may result if motor frame and adjacent metal are not grounded in compliance with electrical code.

## 3-Phase Bills of Materials

Item ID: 8C-T410JBFSCXSAXX-C519ED		
Item Description: T410J BF T21 Cer C/C 1 HP 3/60/208-230/460V 3450 RPM ODP motor		
Item Number	Description	Qty Needed
12-1068-01-457	Type 21 Rotating Element .875" Buna Seal	1
1-2218-0J-543	T41 J Motor Bracket, Teflon Coated	1
2-2208-0J-543	T41 J Cover, Teflon Coated	1
17-1390-01-181	Sleeve, Shaft, Brass	1
15-1168-01-104	Setscrew, 18-8 SS	2
125-1282-01-592	Seal Seat, 0.875 Ceramic, O-Ring Style	1
22-4265-01-101	Plug, 1/8 SAE	1
135-1179-01-457	O-ring, -218 Buna Included w/ Seat	1
7-3970-01-457	O Ring, -902 Buna (Drain Plug)	1
7-2479-01-457	O Ring, -159 Buna	1
FRC-1254-51-ODP	3/4 HP 3/60/230/460V 3450 RPM ODP Bluffton [3/50/190/380--2880]	1
19-1997-01-080	Machine Bolt, 3/8-16 + 4"L	4
23-1487-01-080	Key, Sleeve	1
11-2228-0J-206	Impeller, T41J Bronze	1
23-1022-01-104	Drive Key, 316SS	1
14-1049-01-080	Drive Collar	1

## 3-Phase Motor Nameplate

<b>BLUFFTON MOTOR WORKS</b>		Blank:	
410 E. Spring St. Bluffton, Indiana 46714		MOD 1303017103	REF 125451-ODP
60 HZ	50 HZ	FR 56C	PH 3
HP 1.5	1.5	INS 40	INS B
RPM 3450	2875	ENC D P	CONT
V 208-230/460	190-220/380-440	THE DATE	M
FLA 4.6/4.8/2.4	5.0/5.2/2.5/2.6	ISO CODE	DATE CODE
SF 13	1.0		
SFA 5.5-5.6/2.8	Blank		

Blank:

**LOW VOLTAGE**

**HIGH VOLTAGE**

**WARNING** - Always disconnect motor from power supply before servicing.

**MOTOR CONTAINS NO THERMAL PROTECTOR** - Separate over current protection must be provided to prevent burnout and possible fire hazard from overload or stalled motor.

**GROUNDING** - Fatal electrical shock may result if motor frame and adjacent metal are not grounded in compliance with electrical code.



# MTH PUMPS

401 West Main Street • Plano, IL 60545-1436  
 Phone: 630-552-4115 • Fax: 630-552-3688  
 Email: SALES@MTHPUMPS.COM  
 http://WWW.MTHPUMPS.COM